

2015

# **Cardiac Event Recorder (Loop Recorder)**

# Cardiac Event Recorder (Loop Recorder)

“King of Hearts” type

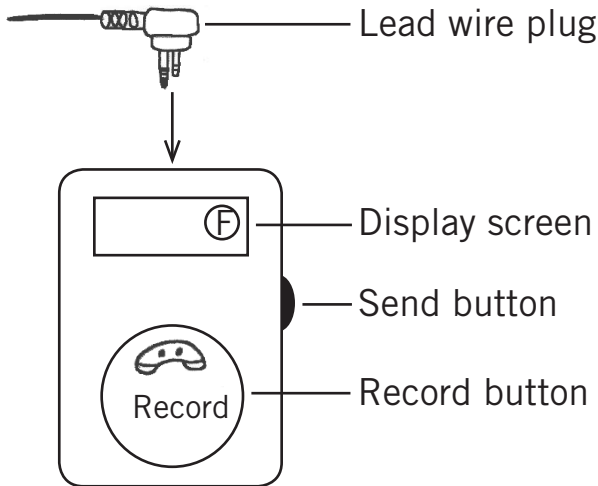

## What is a loop recorder?

- Similar to an electrocardiogram (ECG) test, a cardiac event recorder (loop recorder) records the electrical activity of your heart. However, a loop recorder can do the job while you are at home and going about your usual activities.
- It helps your doctor diagnose heart symptoms that come and go, or happen once in a while.
- The loop recorder only records heart activity when you press a button. Start recording when you feel your symptoms coming on.
- A cardiac technologist will show you how to use the recorder. She or he will also answer any questions you have before you take it home.

## Getting ready

The **electrodes** (small sticky pads) need to be placed firmly on the skin on your chest to get a clear recording.

- Wipe your skin clean with an alcohol swab. Dry the area with the gauze pads given before placing the electrodes on your chest.
- Attach the electrodes to the **lead wires** before placing the electrodes to your chest.
- **Place the electrodes** on your chest in the position shown in the diagram below.
- The white lead wire connects to the right electrode. The black lead wire connects to the left electrode.
- Press the electrodes firmly to your skin.
- Throw away any electrodes that won't stick.
- **Change the electrodes** every day, or more often if they get loose or are not sticking well.
- Put the **plug** from the **lead wires** into the top of the recorder after you have placed the electrodes on your chest.
- Secure the recorder as instructed by the technologist.

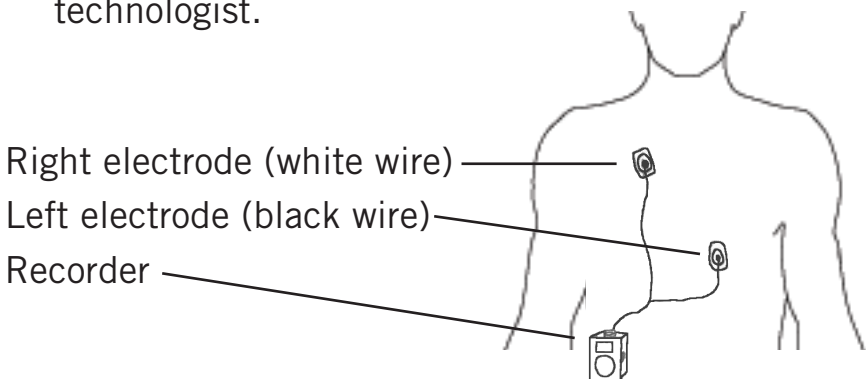

## Recording

- When you have any heart symptoms (such as dizziness, chest pain, palpitations, light-headedness, shortness of breath) press the **RECORD** button on the recorder.
- Relax and stay still while the device is recording.
- You will hear a series of 5 tones or “beeps” which lets you know it has stopped recording.
- After recording, you will see an “F” in the display screen. This means the device memory is full and it cannot record any more. **You must transmit (send in) your recording.** The device will keep beeping every few minutes until you transmit your recording.
- Sometimes, the record button may get pressed by mistake. If so, the device will beep a series of 5 tones and an “F” will appear in the display screen. **You do not need to transmit this recording, but you do need to erase it:**
  - › Unplug the lead wire at the top of your recorder and press the SEND button on the side of the device.
  - › When the whistling sound stops, plug the lead wire back in. This resets the recorder.

If you have any questions, please ask.

We are here to help you.

## Transmitting

- **A landline phone at home is best**, as few cell phones will work with the system.
- Take out the lead wire plug from the top of the recorder.
- Remember:
  - › **Your home phone number is always your identification number.**
  - › The # symbol on your telephone is called the “pound” key.
- Call **902-473-7797** when you are ready to send in your recording. Follow the instructions on the phone which include stating:
  1. Your full name, the date, and the time.
  2. The symptoms you had when you recorded.
  3. Where you were and what you were doing when you recorded.
- Put the recorder face-up on a table or flat surface next to your phone. Put the mouthpiece (the part you speak into) of the phone over the RECORD button of your recorder. Press the SEND button (found on the side) to start the transmission. You will hear a whistling sound.
- After the transmission is done, the whistling sound will stop. You may plug the lead wire back into the recorder.

## **Batteries**

Check the batteries each time you turn on the recorder. If the battery symbol appears on the screen, the battery is low and must be replaced with 2 AAA batteries (2 triple A batteries).

## **Bathing or showering**

You must disconnect the lead wire plug and take off the recorder and electrodes to bathe or shower.

## **If you have problems with your recorder**

- If you have questions or concerns about your recorder, call **902-473-2422** and leave a message on the answering machine.
- A technologist will get your message and will call you back within 24 hours on weekdays (Monday to Friday, 8 a.m.-4 p.m.). If it is the weekend or a holiday, a technologist will call you as soon as possible during the hours just listed.

**If you are concerned about your heart symptoms, contact your doctor.**

### **Returning your device**

- You must return your recorder by:

\_\_\_\_\_

- Return to:  
Cardiac Services, 3rd floor, Halifax Infirmary  
Attention: Holter Lab  
QEII Health Sciences Centre  
1796 Summer St.  
Halifax, NS B3H 3K4

# Notes:

---

---

---

---

---

---

---

---

---

---

---

**Looking for more health information?**

Contact your local public library for books, videos, magazines, and other resources.  
For more information go to <http://library.novascotia.ca>

*Capital Health promotes a smoke-free, vape-free, and scent-free environment.  
Please do not use perfumed products. Thank you!*

**Capital Health, Nova Scotia**  
[www.cdha.nshealth.ca](http://www.cdha.nshealth.ca)

*Prepared by: Cardiac Services  
Illustrations by: Staff;*

LifeART Super Anatomy 1 Images, Copyright © 1994, TechPool Studios Corp. USA  
*Designed by: Capital Health Library Services, Patient Education Team  
Printed by: Dalhousie University Print Centre*

The information in this brochure is provided for informational and educational purposes only.  
The information is not intended to be and does not constitute healthcare or medical advice.  
If you have any questions, please ask your healthcare provider.